

DOUBLE COLUMN MACHINING CENTER

BM-M series

BM 1530M

BM 2035M

BM 2740M

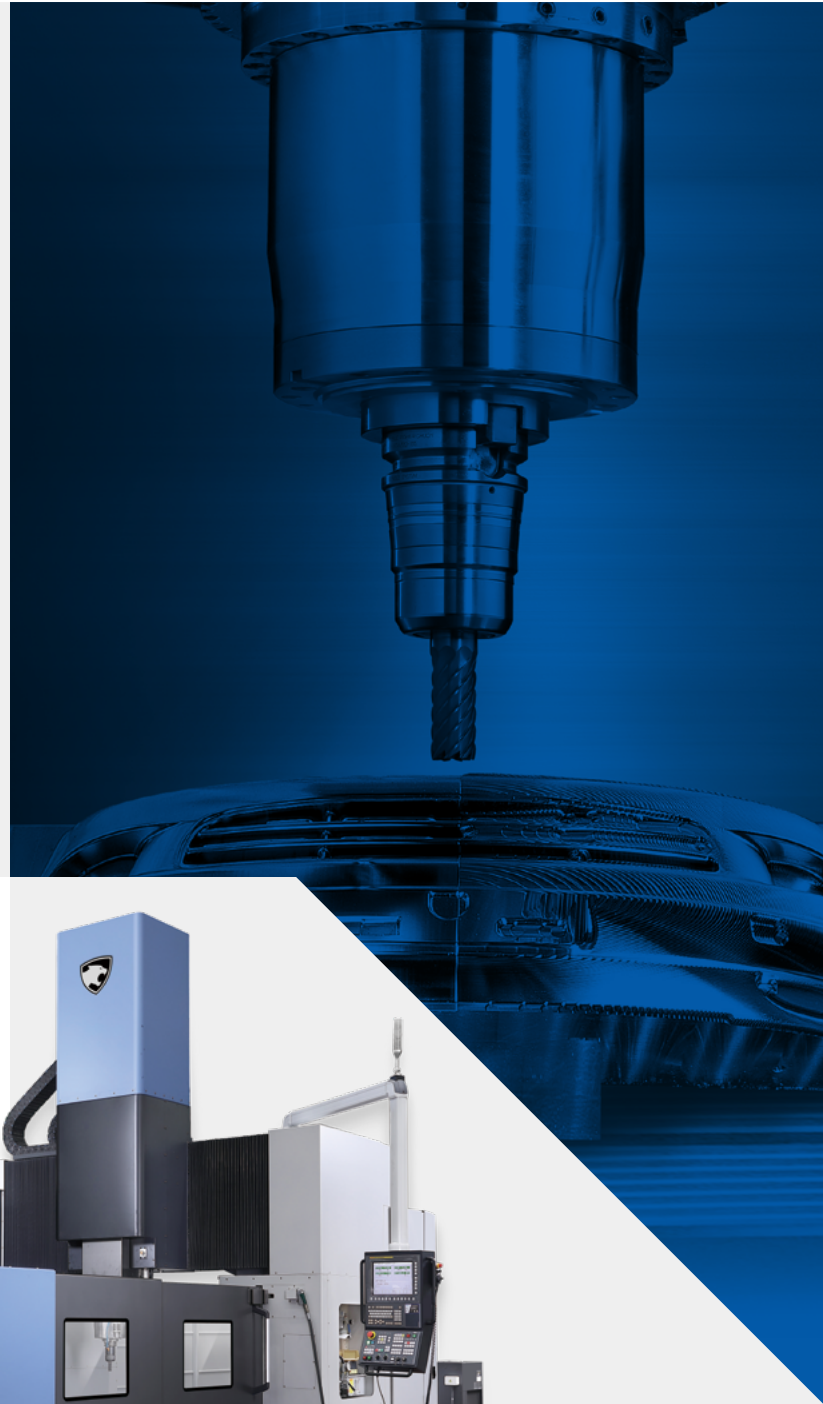

Basic Information

Basic Structure
Cutting
Performance

Detailed Information

Options
Optimized Tool
Processing Solution
Capacity Diagram
Specifications



BM series

The BM Series is a large double-column type machining center designed to process molds. Equipped with a low-vibration built-in spindle, the machining center is suitable for a variety of works from roughing to finishing. The new improved design delivers greater efficiency, thereby raising customers' productivity and creating maximum added value.

Contents

02 Product Overview

Basic Information

04 Basic Structure

07 Cutting Performance

Detailed Information

08 Standard / Optional Specifications

10 Optimized Tool Processing Solution

12 Capacity Diagram

14 Machine / NC Unit Specifications

Equipped with a high-speed, high-rigidity spindle as a standard feature

- 12000 r/min high-speed spindle
- Long-nose type ideal for deep pocket mold cutting
- Equipped with a dual contact spindle as a standard feature for high rigidity and minimum vibration



Standard feed axes equipment for higher level of precision

- All axes provided with a linear scale as a standard feature
- Ball screw bearings and nut cooling system



Adoption of structure and control solution for high-quality mold cutting

- Covers provided to minimize the impact of ambient temperature
- Thermal displacement compensation for spindle and structure included as a standard feature

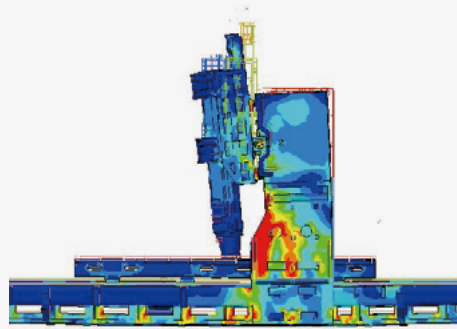

Sample work



Press mold



Injection mold



Refrigerator mold



Automotive mold

Basic Information

Basic Structure
Cutting
Performance

Detailed Information

Options
Optimized Tool
Processing Solution
Capacity Diagram
Specifications



Basic Structure

Double-column structure for stable precision level

Thermal Displacement Compensation for Spindle and Structure Included as a Standard Feature

Multiple thermal sensors are attached to minimize and compensate thermal displacement of the spindle and the structure.

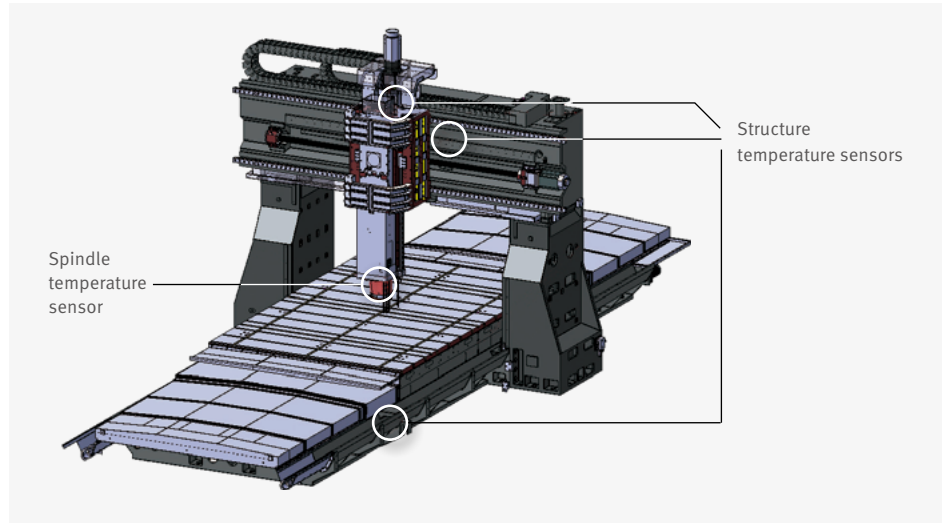

Important parts of the structure are covered to minimize the impact of ambient temperature

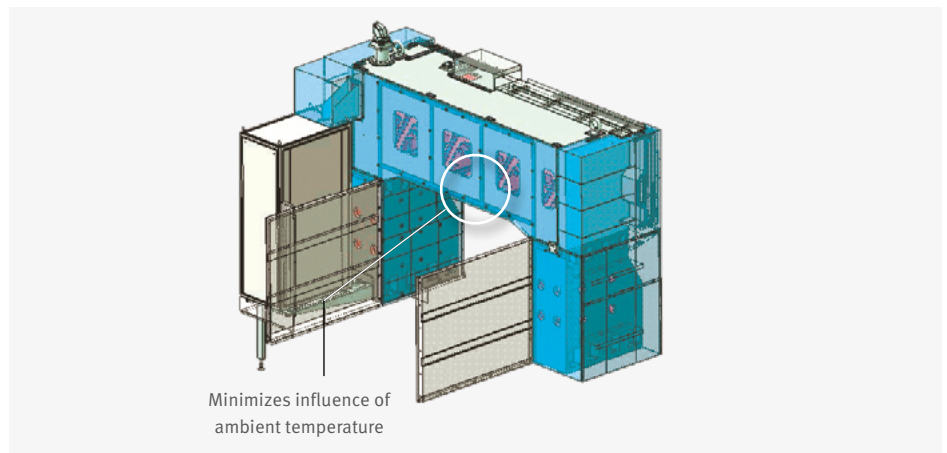

Foundation

Anchoring is recommended to ensure machining accuracy over a long time.

Machine Foundation*

Since machining accuracy is highly dependent on the machine's foundation, anchoring is recommended to maintain accuracy over a long period of time. The anchor bolts and other related parts for foundation work are supplied as standard items.

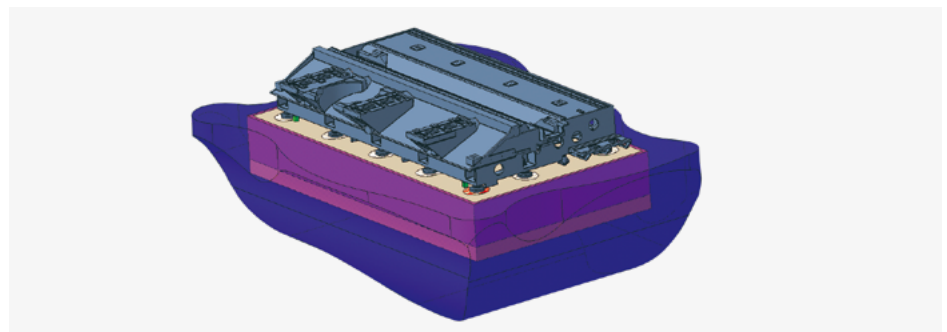

* Please consult with DN Solutions sales technicians regarding ground and operating conditions.

Spindle

A high-speed, high-rigidity built-in spindle is provided as a standard feature to enhance the productivity of machining large works as well as smaller parts.

Built-in Spindle Optimized for Cutting Molds

- Vibration and noise minimized with built-in spindle
- Long-nose spindle protrudes by 293 mm (11.5 inch), making it ideal for cutting deep pocket molds
- Dual contact spindle included as a standard feature for high rigidity and vibration

Advantaged with Deep pocket cutting



Long nose
293mm
(11.5 inch)



Max. spindle speed
12000r/min

Spindle motor
30 / 25kW
(40.2 / 33.5 Hp)

| Type | Speed | Spindle | Specifications |
|---------------------|-------------|----------------------|-----------------------------|
| Built-in ISO #50 | 12000 r/min | Power (30 min/cont.) | 30 / 25 kW (40.2 / 33.5 Hp) |
| | | Max. torque | 420 N·m (310.0 ft-lbs) |

Dual Contact Spindle

Tool rigidity is enhanced by the firm clamping of the spindle. Tool lifecycle and cut-surface roughness have been improved as a result of the reduced vibration realized by the dual contact spindle.

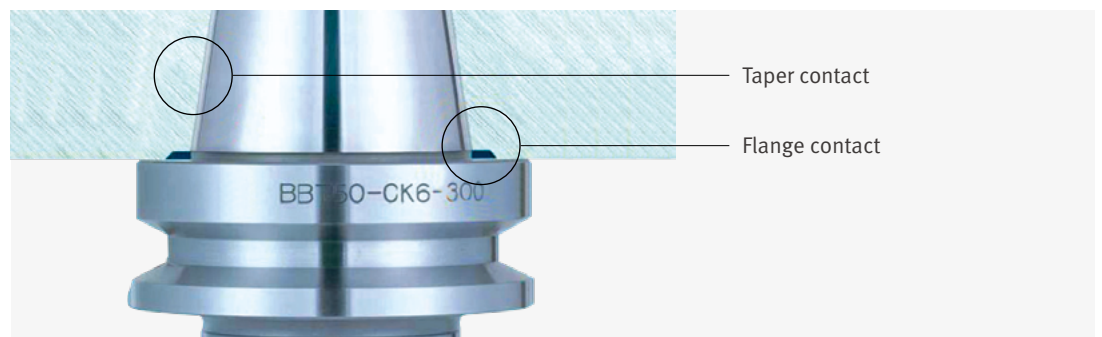

* Universal Head is available : Please contact DN Solutions to select detail specifications



Feed Axes

Equipped with roller LM Guideways for increased rigidity and a cooling system as a standard feature to minimize thermal displacement.

Stable and Fast Feed Shaft Structure

Roller-type LM Guideways deliver high rigidity to guarantee the outstanding accuracy of the linear feed system.

High-rigidity feed system structure

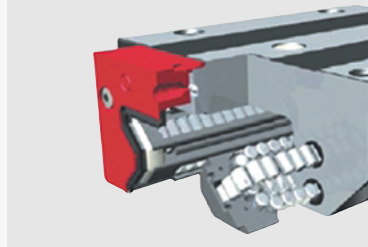

Roller guides

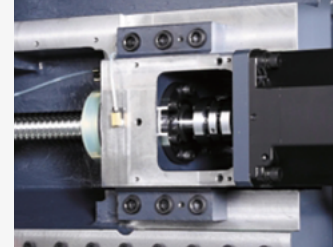

Rigid coupling

Ball screw nut cooling

Greatly reduced thermal displacement of feed shafts
Stable rigidity of the feed system

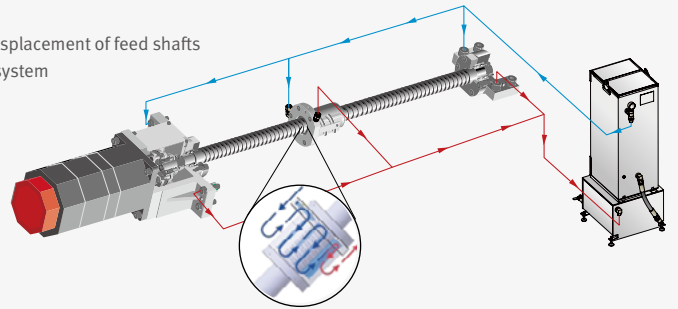

Linear scale – standard for all axes

All axes are equipped with the linear scale as a standard feature to maintain the highest degree of accuracy over many hours of operation.



Additional 200mm (7.9 inch) Y-axis for table self-cutting & extended cutting area.



| Description | Unit | BM 1530M | BM 2035M | BM2740M |
|----------------------------|----------------|--|--|---|
| Stroke (X / Y / Z) | mm (inch) | 3000 / 1550 / 800 (118.1 / 61.0 / 31.5) | 3500 / 2050 / 800 (137.8 / 80.7 / 31.5) | 4000 / 2700 / 800 (157.5 / 106.3 / 31.5) |
| Rapid traverse (X / Y / Z) | m/min (ipm) | 16 / 16 / 16 (629.9 / 629.9 / 629.9) | 16 / 16 / 16 (629.9 / 629.9 / 629.9) | 12 / 16 / 16 (472.4 / 629.9 / 629.9) |



Magazine and Table

Tool Magazine

Enhanced productivity realized with the CAM-type tool changer (standard) for quicker tool changing.

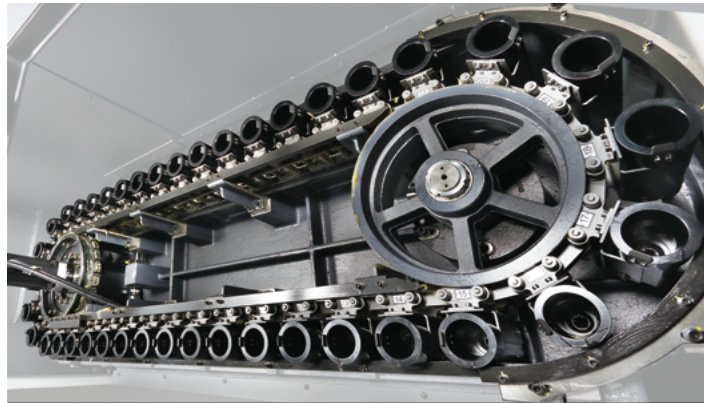

| Description | Unit | BM Series | Max. tool diameter | mm (inch) | 125 / 220 (4.9 / 8.7) |
|-----------------------|------|-----------|--------------------|-----------|-----------------------|
| Tool storage capacity | ea | 40 {60} | Max. tool length | mm (inch) | 400 (15.7) |
| Tool-to-Tool | sec | 3.0 | Max. tool weight | kgf (lbs) | 20 (44.1) |

The table is fitted with 2 or 3 lanes of roller-type LM Guideways for highest machining stability.

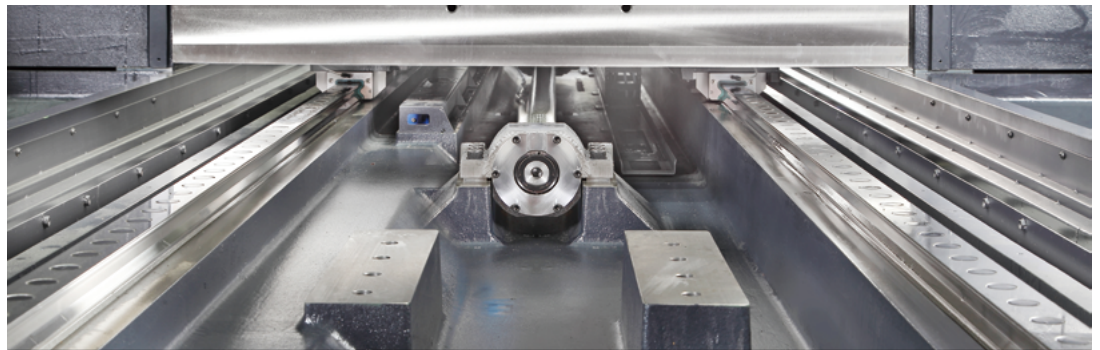

| Description | Unit | BM1530M | BM 2035M | BM 2740M |
|---------------|-----------|----------------------------|----------------------------|----------------------------|
| Size (X x Y) | mm (inch) | 3000 x 1350 (118.1 x 53.1) | 3500 x 1850 (137.8 x 72.8) | 4000 x 2500 (157.5 x 98.4) |
| Load capacity | kgf (lbs) | 8000 (17637.0) | 10000 (22046.2) | 15000 (33069.3) |



Cutting Performance

Machining Performance

Enhanced productivity realized with the CAM-type tool changer (standard) for quicker tool changing.

| Cutting Process | Tool mm (inch) | Spindle Speed r/min | Feedrate mm/min (ipm) | Cutting capability cm ³ /min (inch) |
|---------------------|-------------------|------------------------|--------------------------|---|
| FACEMILL (SM45C) | D125 (D4.9) | 500 | 2900 (114.2) | 820 (50.0) |
| | | 500 | 1800 (70.9) | 720 (43.9) |
| | | 500 | 1300 (51.2) | 650 (39.7) |
| | | 500 | 1100 (43.3) | 660 (40.3) |
| | | 400 | 720 (28.3) | 504 (30.8) |
| Cutting Process | Tool mm (inch) | Spindle Speed r/min | Feedrate mm/min (ipm) | Cutting capability cm ³ /min (inch) |
| U-DRILL | D70 (D2.8) | 500 (2.9) | 170 (6.7) | 654 (39.9) |
| TAP | M42 x 4.5 | 113 (4.4) | 508 (20.0) | 50 (3.1) |

* The results, indicated in this catalogue are provides as example. They may not be obtained due to differences in cutting conditions and environmental conditions during measurement.

Basic Information

Basic Structure
Cutting
Performance

Detailed Information

Options
Optimized Tool
Processing Solution
Capacity Diagram
Specifications



Standard / Optional Specifications

Various options are available to satisfy the customers' requirements.

● Standard ○ Optional

| NO. | Description | Features | BM Series |
|-----|--|---|-----------|
| 1 | Spindle | 12000 r/min, 30 / 25 kW (30min / Cont.) | ● |
| 2 | | FLOOD COOLANT PUMP_0.45 MPA | ● |
| 3 | | FLOOD COOLANT PUMP_0.7MPa | ○ |
| 4 | | THROUGH SPINDLE COOLANT_None | ● |
| 5 | | THROUGH SPINDLE COOLANT_2.0 MPA_20L/min | ○ |
| 6 | | THROUGH SPINDLE COOLANT_2.0 MPA_30L/min | ○ |
| 7 | | THROUGH SPINDLE COOLANT_7.0 MPA_20L/min | ○ |
| 8 | Travels | LINEAR SCALE (X, Y, Z-AXIS) | ● |
| 9 | | RAISING BLOCK 300 mm | ○ |
| 10 | Magazine | MAGAZINE CAPACITY: 40 TOOLS | ● |
| 11 | | MAGAZINE CAPACITY: 60 TOOLS | ○ |
| 12 | Control System | FANUC 31i-B PLUS | ● |
| 13 | | AICC IL_1000 BLOCKS | ● |
| 14 | | Fast Data server with 1GB PCMCIA card | ○ |
| 17 | | EXTRA M CODE | ○ |
| 18 | | FLASH MEMORY CARD | ○ |
| 19 | Others | SEMI SPLASH GUARD ¹⁾ | ● |
| 20 | | FULL SPLASH GUARD | ○ |
| 21 | | OIL SKIMMER | ○ |
| 22 | | COOLANT GUN | ● |
| 23 | | Water soluble Coolant Chiller** | ○ |
| 24 | | CHIP CONVEYOR | ○ |
| 25 | | AIR BLOWER | ● |
| 26 | | AIR GUN | ○ |
| 27 | | AIR CONDITIONER | ○ |
| 28 | | ELECTRIC CABINET LIGHT | ○ |
| 29 | | WORK & TOOL COUNTER | ○ |
| 30 | | 1 MPG | ● |
| 31 | | 3 MPG | ○ |
| 32 | | LCD Display MPG | ○ |
| 33 | | TRANSFORMER | ○ |
| 34 | | 3-STAGE SIGNAL TOWER | ● |
| 35 | | WORK LIGHT | ● |
| 36 | Coolant level switch : Sensing level - Low *** | ○ | |

* Please contact your DN Solutions representative for detailed machine information. *** Special Quotation.

** Technical consultation is mandatory for the chilling of non-water soluble coolant

* When using a semi-synthetic type or synthetic type, contact our sales representative or service center in advance.

1) Add Splash Guard option to provide workers protection and to prevent the scattering of coolant oil. If Splash Guard option is not selected, then it is highly advised for customers to prepare separate protective measures

Optional Devices

Various solutions are available for better machining performance and higher-quality.

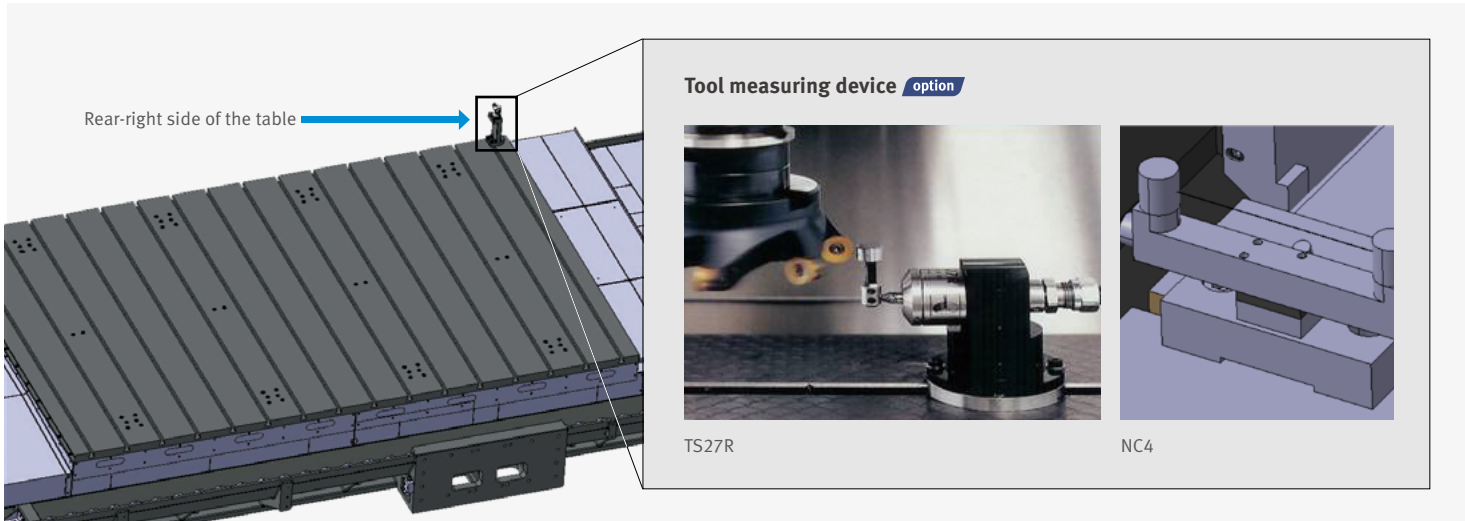

MPG MPG suitable for large works



Manual handle Portable
MPG



Manual handle Portable 3 MPG
option



Manual handle MPG with LCD
option



Manual operation panel option
HMOP
(Handy Machine Operator's Panel)

3-Stage Signal Tower



- Warning lamp**
Reports abnormal operational conditions of the machine
- Work completion indicator**
Indicates that the work has been completed
- In-progress lamp**
Indicates that the work is being carried out

Linear scale



Power saving function

This function saves electricity when the machine is not in use.

Swing arm MAC (Manual Attachment Change)



Optimized Tool Processing Solution

Superior surface finishes and machining accuracy are achieved through using standard processing solutions such as high-speed / high-precision contour control and thermal displacement compensation.

DSO High Speed / High Precision Contour Control

- AICC2_1000 BLOCK + Machining condition selection function (Standard)
- Data server 1GB or 2GB **option**

DAFC The Optimal Feed Control **option**

* DAFC : DN Solutions Adaptive Feedrate Control

Optimal feed control is ensured by real-time spindle load detection.

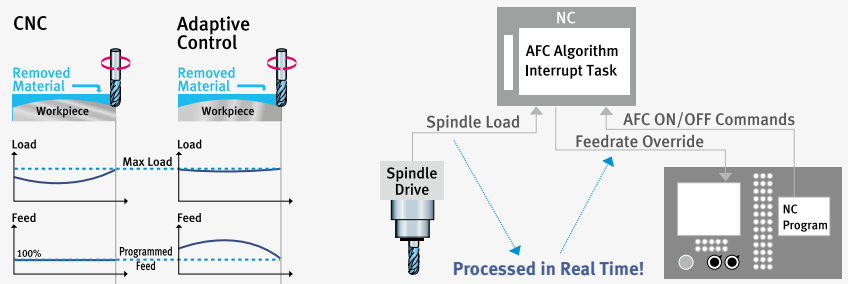

DTMM Tool Load Monitoring System (DTMM*) **option**

* DTMM : DN Solutions Tool load Monitoring for Machining Centers

The technology of protecting tool and machine in abnormal load during the cutting process

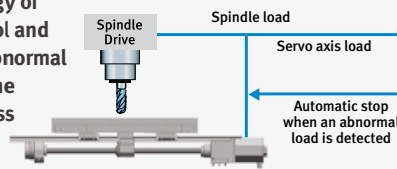

- DTMM* software
- ✓ Detection cycle = Program interpolation cycle
 - ✓ Automatic stop when an abnormal load is detected
 - ✓ Select an alternative tool and command to NC

DSTC Smart thermal displacement multi compensation technology

* DSTC : DN Solutions Smart Thermal Control

Realizes high-quality, high-precision machining with smoothing thermal displacement compensation of the spindle and structure.

Compensation of static displacement of spindle

Compensates changes in tool position caused by expansion of the spindle shaft at high speed.

Structure thermal displacement compensation

Compensates irregular deflection or expansion of the structure due to ambient temperature using a multiple temperature sensors.

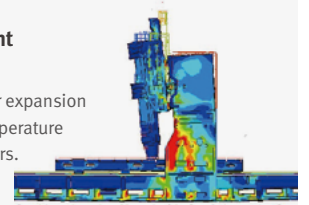

Compensation of structure thermal displacement

Thermal error of the spindle caused by heat accumulation is compensated with 5 algorithms including a smoothing function.

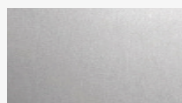

Without smoothing

With smoothing

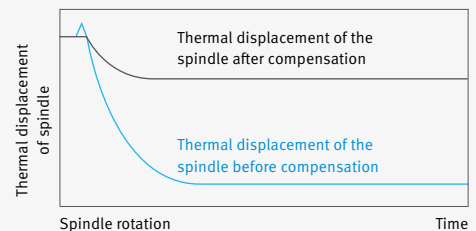

FANUC 31iB PLUS

FANUC 31iB PLUS maximizes customer productivity and convenience.

15" Touch screen + New OP

DN Solutions Fanuc 31iB/B5 Plus' operation panel enhances operating convenience by incorporating commondesign buttons and layout. It features a Qwerty keyboard for fast and easy data input and operation.



FANUC 31iB PLUS

- 15-inch color display
- Intuitive and user-friendly design

USB & PCMCIA card QWERTY keyboard

- EZ-Guide i standard
- Ergonomic operator panel
- 4MB Memory
- Hot keys
- Enhance AICC BLOCK
- Touch pen provided as standard



iHMI touchscreen

- iHMI provides an intuitive interface that uses a touchscreen for quick and easy operation.

Range of applications

- Providing various applications related to planning, machining, improvement and utility, for customer convenience.

EZ work

Tool load monitoring, Setup guide, Status monitoring, Operation and Recovery guide can provide more convenience and efficiency increasing for user operation.



Thermal Compensation
A function to maintain high-precision machining quality by analyzing and correcting the amount of thermal displacement of a structure through a temperature sensor



M/G-Code List
Functional description of M code and G code



Tool Management
Function to manage tool information [Tool information / Tool No. / Tool condition (normal, large diameter, worn / damaged, used for the 1st time, manual) / Tool name]



Operation Rate
Machine operation history management function by date based on load



Spindle Warm Up
A function that assists spindle warm-up for spindle life when the spindle has not been used for a certain period of time



Adaptive Feed Control
Function to control feedrate so that the cutting can be carried out at a constant load



ATC Recovery
Function to view detailed info with recommended actions and to perform step-by-step operation manually (when an alarm is triggered during an ATC operation)

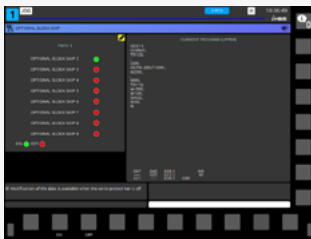

Addition of Optional Block Skip
In addition to the OPTIONAL BLOCK SKIP of the operation panel, the function to skip a specific block selected in the machining program

Product Preview

Basic information

Basic Structure
Cutting
Performance

Detailed Information

Options
Diagrams
Specifications

Customer Support Service



Siemens SINUMERIK ONE

Even Faster & Easier processing +21.5" screen

All programming, set-up, actual machining and verification process are getting easier and faster. Especially, intuitive conversational programming guidance with 3D UI(user interface) on 21.5" large touch screen is helpful for unskilled engineers.



- 21.5 inch touch screen
- 50% improvement in processing speed (compared to S840D)
- Graphic programming
- PLC-based flexible automation/peripheral device expandability



EZ work

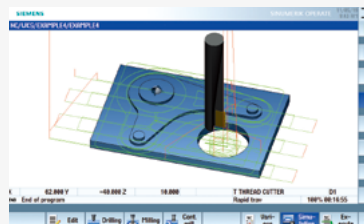

Simulation and machining contour monitoring

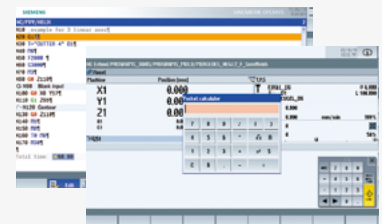

Smart function

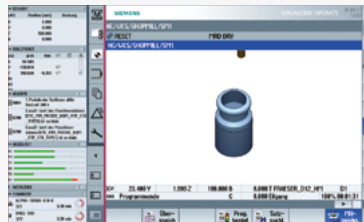

Side screen widget

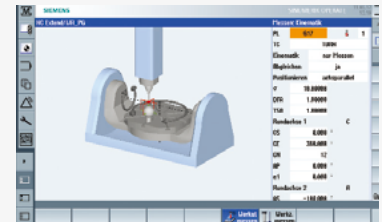

5-axis kinematic measuring Shop mill part programming cycles

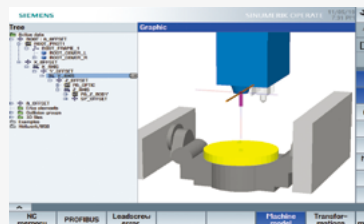

3D collision avoidance and collision avoidance ECO

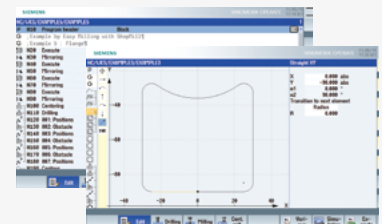

Shop mill part programming

Heidenhain TNC7

Visualized, intuitive task support, customized UI

The TNC7 makes machining even easier, for everything from programming to program validation and from machine setup to actual machining. You intuitively operate highly complex applications directly on the touchscreen with various integrated solutions for standard tasks.



TNC7 NEW

- 24 inch touch screen
- 189GB Program memory
- Look-ahead 5000 blocks
- Touch Probe Cycles
Graphical Programming

EZ work

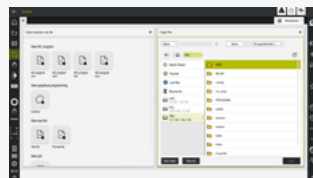

Data are controlled in the folder structure; convenient communication via USB devices

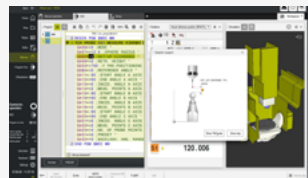

KinematicOpt & KinematicComp (Touch probe cycle for automatic measurement) option

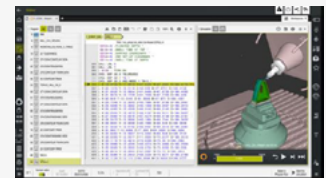

Graphic simulation

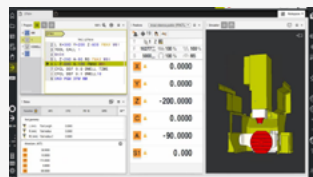

Collision protection system option

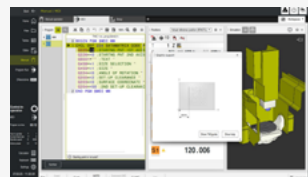

Various built-in pattern cycles
Graphic simulation for a wider scope of application (Software standard)

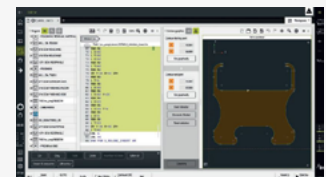

Highly practical programming and setup based on touch operation



Enhanced collision protection function DCMv2 option



Improved maintenance environment

Power-Torque Diagram / Tool Shank

Basic Information

Basic Structure
Cutting
Performance

Spindle Power – Torque Diagram

12000 r/min

spindle speed **12000r/min**
Spindle motor **30 / 25kW**
(40.2 / 33.5 Hp)

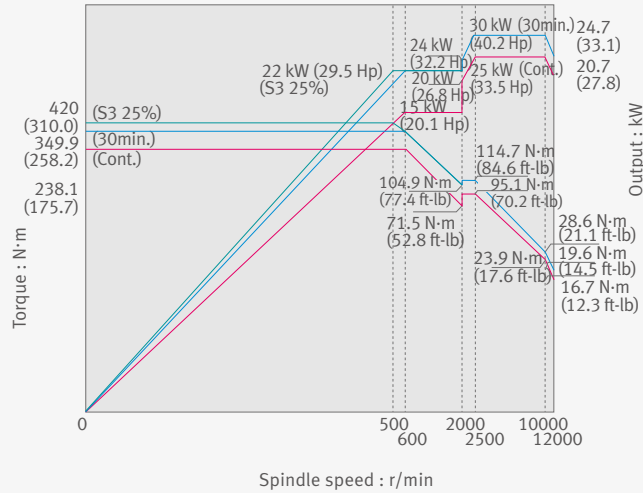

Tool Shank

BT 50

CAT 50

DIN 50

Unit: mm (inch)

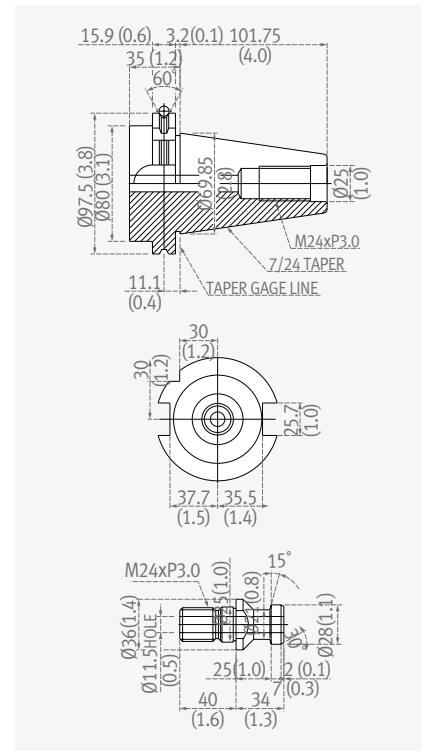
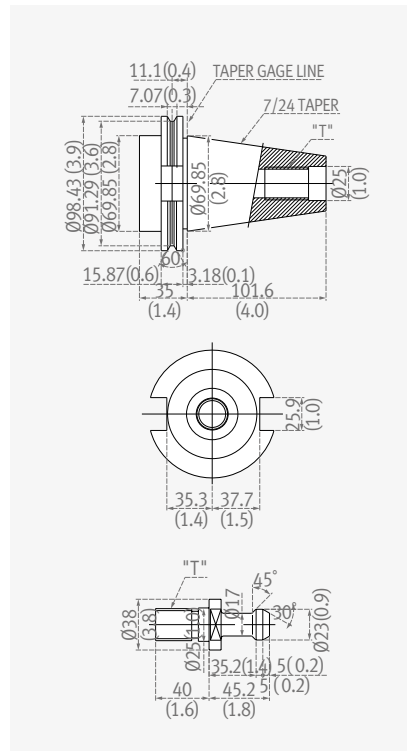
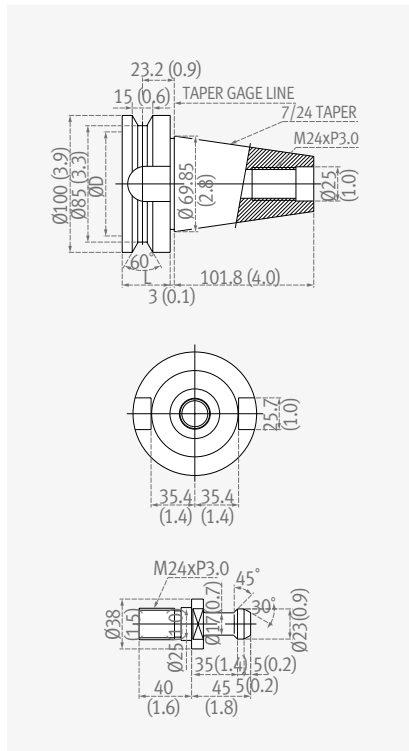

External Dimensions / Table

External Dimensions

Unit: mm (inch)

Top View

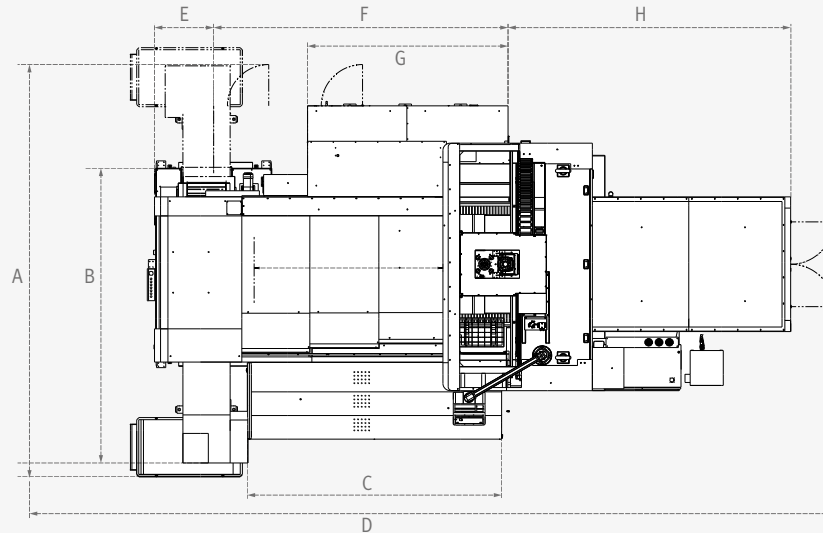

Front View

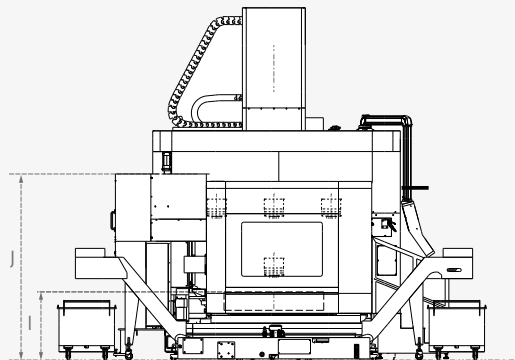

* Please comply with our company's installation guideline, such as ground condition and anchoring, in order to achieve the maximum precision and performance of the machine.

| Model | A | B | C | D | E | F | G | H | I | J | K |
|----------|--------------|---------------|--------------|--------------|--------------|--------------|-------------|-------------|------------|-----------|-------------|
| BM 1530M | 5650 (222.4) | 9570 (376.8) | 2840 (111.8) | 2810 (110.6) | 4850 (190.9) | 4720 (185.8) | 2715(106.9) | 3826(150.6) | 2520(99.2) | 923(36.3) | 4810(189.4) |
| BM 2035M | 6200 (244.1) | 10450 (411.4) | 3180 (125.2) | 3020 (118.9) | 5310 (209.1) | 5140 (202.4) | 2715(106.9) | 4244(167) | 2520(99.2) | 923(36.3) | 4810(189.4) |
| BM 2740M | 6550 (257.9) | 11700 (460.6) | 3220 (126.8) | 3330 (131.1) | 6080 (239.4) | 5620 (221.3) | 2715(106.9) | 4735(186.4) | 2520(99.2) | 923(36.3) | 4790(188.6) |

* Some peripheral equipment can be placed in other places

** Providing anchoring bolts. Foundation work must be done.

Table

Unit: mm (inch)

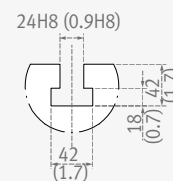
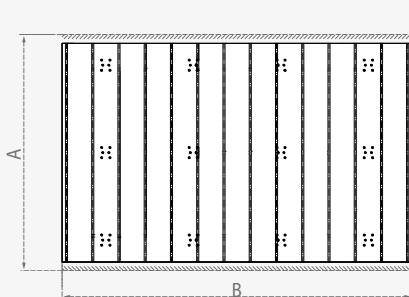

| Model | A | B | C | T-SLOT distance | Quantity |
|----------|-------------|--------------|-----------|-----------------|----------|
| BM 1530M | 1350 (53.1) | 3000 (118.1) | 210 (8.3) | 300 | 10 ea |
| BM 2035M | 1850 (72.8) | 3500 (137.8) | 210 (8.3) | 300 | 11 ea |
| BM 2740M | 2500 (98.4) | 4000 (157.5) | 210 (8.3) | 300 | 14 ea |

* T-slot direction can be changed

Machine Specifications

Basic Information

Basic Structure
Cutting
Performance

Detailed Information

Options
Optimized Tool
Processing Solution
Capacity Diagram
Specifications



| Description | | Unit | BM 1530M | BM 2035M | BM2740M |
|--------------|---|--------------|---|--|---|
| Travel | X-axis | mm (inch) | 3000 (118.1) | 3500 (137.8) | 4000 (157.5) |
| | Y-axis | mm (inch) | 1550 (61.0) | 2050 (80.7) | 2700 (106.3) |
| | Z-axis | mm (inch) | 800 (31.5) | 800 (31.5) | 800 (31.5) |
| Table | Spindle to table surface | mm (inch) | 200~1000 (7.9~39.4) | | 150~950 (5.9~37.4) |
| | Distance between columns | mm (inch) | 1700 (66.9) | 2200 (86.6) | 2700 (106.3) |
| | Table size | mm (inch) | 3000 x 1350 (118.1 x 53.1) | 3500 x 1850 (137.8 x 72.8) | 4000 x 2500 (157.5 x 98.4) |
| | Loading capacity | kg (lb) | 8000 (17636.7) | 10000 (22045.9) | 15000 (33068.9) |
| | Table surface | - | T-SLOT (10-300 x 24H8) | BM2035M : T-SLOT (11-300x24H8) BM2740M : T-SLOT (14-300x24H8) | |
| Spindle | Speed | r/min | 12000 | | |
| | Taper | - | ISO #50, 7/14 | | |
| | Max. torque | N·m (ft·lb) | 420(310.0) | | |
| | Spindle power | kW (Hp) | 30/25(40.2/33.5) | | |
| Feed rate | Rapid feedrate (X / Y / Z) | m/min (ipm) | 16 / 16 / 16 (629.9 / 629.9 / 629.9) | | 12 / 16 / 16 (472.4 / 629.9 / 629.9) |
| | Cutting feedrate | mm/min (ipm) | 8000 (315.0) | | 6000 (236.2) |
| ATC | Tool shank type | - | BT / CAT / DIN 50 | | |
| | Tool storage capacity | ea | 40 {60}* | | |
| | Max. tool diameter [w/o adjacent tool] | mm (inch) | 125 [220] (4.9 [8.7]) | | |
| | Max. tool length | mm (inch) | 400 (15.7) | | |
| | Max. tool weight | kg (lb) | 20 (44.1) | | |
| | Max. tool moment | N·m (ft·lb) | 22(16.23) | | |
| | Tool selection type | - | MEMORY RANDOM | | |
| | Tool change time (T-T) | s | 3.0 | | |
| Machine Size | Height | mm (inch) | 4770 (187.8) | 4770 (187.8) | 4675 (184.1) |
| | Dimension (L x W) | mm (inch) | 8690 x 4450 (342.1 x 175.2) | 9540 x 4960 (375.6 x 195.3) | 10825 x 5535 (426.2 x 217.9) |
| | Weight | kg (lb) | 29000 (63933.1) | 35500 (78262.9) | 48000 (105820.3) |

* { } : Option

NC Unit Specifications

● Standard ○ Optional X N/A ✚ Available

F31iB Plus

| 구분 | 항목 | 상세 | BM 1530M/2035M/2740M |
|-----------------------------|---|--|-------------------------|
| | | | F31iB PLUS |
| Controlled axis | Controlled axes | | 3 (X,Y,Z) |
| | Simultaneously controlled axes | | 3 axes |
| | Additional controlled Axis | Add 1 Axis (5th Axis) | ○ |
| Data input/output | Fast data server | | ●(1GB) |
| | Memory card input/output | | ● |
| | USB memory input/output | | ● |
| | Large capacity memory(2GB) ¹² | Available Option only with 15" Touch LCD (iHMI Only) *2) | ○ |
| Interface function | Embedded Ethernet | | ● |
| | Fast Ethernet | | ○ |
| | Enhanced Embedded Ethernet function | | ● |
| Operation | DNC operation | Included in RS232C interface. | ● |
| | DNC operation with memory card | | ● |
| Program input | Workpiece coordinate system | G52 - G59 | ● |
| | Addition of workpiece coordinate system | G54.1 P1 X 48 (48 pairs) | ● |
| | Tool number command | | T4 digits |
| | Tilted working plane indexing command | G68.2 TWP | X |
| Feed function | AI contour control I | G5.1 Q, 40 Blocks | X |
| | AI contour control II | G5.1 Q, 200 Blocks | X |
| | AI contour control II | G5.1 Q, 600 Blocks | X |
| | AI contour control II | G5.1 Q, 1000 Blocks *1) | ● |
| | High smooth TCP | | X |
| Operation Guidance Function | EZ Guidei (Conversational Programming Solution) | | ● |
| | iHMI with Machining Cycle | Only with 15" Touch LCD standard *2) | ● |
| | EZ Operation package | | ● |
| Setting and display | CNC screen dual display function | | ● |
| Network | FANUC MTConnect | | ✚ |
| | FANUC OPC UA | | ✚ |
| Others | Display unit | 15" color LCD | X |
| | | 15" color LCD with Touch Panel | ● |
| | Part program storage size & Number of registerable programs | 640M(256KB)_500 programs | X |
| | | 1280M(512KB)_1000 programs | X |
| | | 2560M(1MB)_1000 programs | X |
| | | 5120M(2MB)_1000 programs | X |
| | | 10240M(4MB)_1000 programs | ● |
| | | 20480M(8MB)_1000 programs | ○ |
| | | 2560M(1MB)_2000 programs | ○ |
| | | 5120M(2MB)_4000 programs | ○ |
| 10240M(4MB)_4000 programs | ○ | | |
| 20480M(8MB)_4000 programs | ○ | | |

Responding to Customers Anytime, Anywhere

DN Solutions' Global Network, Responding to Customer's Needs nearby, Anytime, Anywhere

DN Solutions provides a system-based professional support service before and after the machine tool sale by responding quickly and efficiently to customers' demands. By supplying spare parts, product training, field service and technical support, we can provide top class support to our customers around the world.



Global Sales and Service Support Network

| Countries | + Sales networks | Factories | Service posts |
|-----------|------------------|-----------|---------------|
| 66 | 140 | 3 | 6 |

DN Solutions Customer Support Service

We help customers to achieve success by providing a variety of professional services from pre-sales consultancy to post-sales support.



Supplying Parts

- Supplying a wide range of original DN Solutions spare parts
- Parts repair service



Field Services

- On site service
- Machine installation and testing
- Scheduled preventive maintenance
- Machine repair



Technical Support

- Supports machining methods and technology
- Responds to technical queries
- Provides technical consultancy



Training

- Programming / machine setup and operation
- Electrical and mechanical maintenance
- Applications engineering





Head Office

19F, 10, Tongil-ro, Jung-gu, Seoul,
Republic of Korea, 04527

Tel: +82-2-6972-0370
Fax: +82-2-6972-0400

DN Solutions America

360 E State PKWY,
Schaumburg, IL. 60173,
United states

Tel: +1-315-265-7500

DN Solutions Europe

Emdener Strasse 24, D-41540
Dormagen, Germany

Tel: +49-2133-5067-100
Fax: +49-2133-5067-111

DN Solutions India

No.82, Jakkuar Village
Yelahanka Hobil,
Bangalore-560064

Tel: +91-80-2205-6900
E-mail: india@dncompany.com

DN Solutions China

Room 101,201,301,
Building 39 Xinzhuan Highway
No.258 Songjiang District
China Shanghai (201612)

Tel: +86 21-5445-1155
Fax: +86 21-6405-1472

DN Solutions Vietnam

M.O.R.E building 2F, 40A-40B Ut
Tich Street, 04 Ward 04,
District Tan Binh District,
Ho Chi Minh City, Vietnam

Tel: +84 28-7304-0163

DN Solutions Mexico

Avenida Parque Bicentenario
#100 Nave M65L3-6,
Fraccionamiento San Isidro
Business Park,
Santa Rosa Jauregui,
Querétaro, México

E-mail: efrain.figueroa@dncompany.com

Sales inquiry

sales@dncompany.com